

Data Bulletin

Codes and Standards Application Data—Transformers, Secondary Conductors, and Overcurrent Protection

Application of Overcurrent Protection Rules to Transformers and Primary and Secondary Conductors

Class 0110

INTRODUCTION

A common question is whether transformers, transformer secondary conductors, and overcurrent protection are independent components or parts of a system. The answer to this question is often unclear. A common error is to try and apply a single set of overcurrent protection rules for the transformer to its primary and secondary conductors. This can lead to an installation that does not provide proper conductor protection in accordance with the appropriate NEC® (National Electrical Code) rules.

Solutions to this question can be found in the 2002 NEC rules. The intent of this paper is not to convey the best *design* of a system for any particular application, but to provide examples necessary to understand the code rule “minimums” that must be considered when these components are involved. Designers need to consider other factors for the system, such as desired levels of short-circuit protection, transformer operating characteristics, and coordination.

TRANSFORMERS

Article 450 of the NEC deals with requirements for transformers. Specifically, 450.3 covers OCP (overcurrent protection) requirements for the transformer. Realize that examples given will show maximum OCP values and that devices sized smaller than these maximums may be desired for design purposes. This choice of a lower value can be influenced by actual transformer load, manufacturer recommendations, transformer design, and system functionality.

Article 450 deals ONLY with requirements for the transformer. Ampacity of conductors feeding to and extending from the transformer, as well as necessary overcurrent protection of the conductors are covered under the rules in NEC Chapters 2 and 3. Although the specified OCP for the transformer may be adequate for the conductors, this can only be determined after looking at the applicable rules for the conductors. Also, Article 450 does not specify the location of the OCP for the transformer, which provides some flexibility in providing this OCP. For now, this discussion will only look at what is required for the transformer; the requirements for conductors will be considered in the next section.

Details of transformer OCP focus on the following four basic requirements:

1. **Condition**—determines under what circumstances you can use the given rules. These include items such as location limitation and transformer impedances.
2. **Primary OCP Size**—specifies the maximum rating of the overcurrent device as a percent of transformer primary current.
3. **Secondary OCP Size**—specifies the maximum rating of the overcurrent device as a percent of transformer secondary current. Specific conditions will determine if this overcurrent protection is required. When the protection is required, the *Code* does permit the protection to be a single set of fuses or a circuit breaker or a combination of not more than six sets of fuses or circuit breakers. If multiple overcurrent devices are used, their combined ratings shall not exceed the permitted rating of a single device. For example, if a 600 A circuit breaker would meet the sizing rules for secondary protection of a transformer, then protection could also be provided by six 100 A circuit breakers grouped in one location.



If a combination of fuses and breakers are used, then the combined rating cannot exceed that allowed for fuses.

4. **Next Standard Size Permitted**—specifies if, under the particular condition noted, the next standard OCP device may be used when the maximum size does not correspond to a standard rating or setting.

600 Volts and Less

For 600 volts and less, standard ratings for circuit breakers and fuses can be found in NEC 240.6 and applied as follows: Transformer primary current is 118 amperes and a fuse rating of 125% is permitted, then a 150 A fuse would be the next standard size (118 multiplied by 1.25 = 148, rounding up to next standard size of 150 A). Note that the 800 A limitation on rounding up does not apply to the transformer as it does for conductors in Article 240.

Over 600 Volts

Above 600 V, Article 450 does permit rounding up to next standard ratings in certain instances. This raises the question of where to find standard ratings for overcurrent devices above 600 V. According to the scope of Article 240 (240.1), the standard ratings in 240.6 are applicable to 600 V and less applications. No standard ratings are given in the over 600 V portion of Article 240 (Part IX).

Fuses are available in various sizes with differing ratings. The most popular is the "E" rated fuse. The meaning of these ratings and the "standard sizes" can be found in ANSI/IEEE C37.46. In the majority of cases, it is not necessary to use the next higher fuse rating since a lower rating will likely be selected to provide necessary short circuit protection for the particular transformer involved.

Circuit breakers used for above 600 V applications generally have many schemes to adjust trip characteristics to meet system design parameters. Although the frame sizes are few, the settings provided can be utilized to determine the next standard size. An example of using the next standard size can be found when looking at overcurrent relay "taps" and rounding up to the next tap where the permitted value falls between two tap settings.

NEC 450.3—TRANSFORMER PROTECTION

Two tables provide the guidance for proper overcurrent protection of a transformer.

Over 600 Volts, Nominal—450.3(A)

This table applies to transformers that have a voltage rating greater than 600 V on the primary, secondary, or both.

**Table 1: 450.3(A) Maximum Rating or Setting of Overcurrent Protection for Transformers Over 600 Volts
(As a Percentage of Transformer-Rated Current)**

| Location Limitations | Transformer Rated Impedance | Primary Protection Over 600 Volts | | Secondary Protection (See Note 2) | | |
|--|------------------------------------|-----------------------------------|----------------------|-----------------------------------|----------------------|--------------------------------|
| | | Circuit Breaker (See Note 4) | Fuse Rating | Over 600 Volts | | 600 Volts or Below |
| | | | | Circuit Breaker (See Note 4) | Fuse Rating | Circuit Breaker or Fuse Rating |
| Any location | Not more than 6% | 600% (See Note 1) | 300% (See Note 1) | 300% (See Note 1) | 250% (See Note 1) | 125% (See Note 1) |
| | More than 6% and not more than 10% | 400% (See Note 1) | 300% (See Note 1) | 250% (See Note 1) | 225% (See Note 1) | 125% (See Note 1) |
| Supervised locations only (See Note 3) | Any | 300% (See Note 1) | 250% (See Note 1) | Not required | Not required | Not required |
| | Not more than 6% | 600% | 300% | 300% (See Note 5) | 250% (See Note 5) | 250% (See Note 5) |
| | More than 6% and not more than 10% | 400% | 300% | 250% (See Note 5) | 225% (See Note 5) | 250% (See Note 5) |

Notes:

- Where the required fuse rating or circuit breaker setting does not correspond to a standard rating or setting, the next higher standard rating or setting shall be permitted.
- Where secondary overcurrent protection is required, the secondary overcurrent device shall be permitted to consist of not more than six circuit breakers or six sets of fuses grouped in one location. Where multiple overcurrent devices are utilized, the total of all the device ratings shall not exceed the allowed value of a single overcurrent device. If both breakers and fuses are utilized as the overcurrent device, the total of the device ratings shall not exceed that allowed for fuses.
- A supervised location is a location where conditions of maintenance and supervision ensure that only qualified persons will monitor and service the transformer installation.
- Electronically actuated fuses that may be set to open at a specific current shall be set in accordance with settings for circuit breakers.
- A transformer equipped with a coordinated thermal overload protection by the manufacturer shall be permitted to have separate secondary protection omitted.

This table has two “conditions” that affect its application. One is whether or not the installation can be considered supervised. Note 3 states “where conditions of maintenance and supervision assure that only qualified persons will monitor and service the installation” “Supervised” is more than just having a qualified person install the system. The implication of supervised means that qualified persons are on-site at all times and available to deal with any circumstances that arise with the transformer installation. Before applying these rules, the engineer or designer should contact the authority having jurisdiction to agree that the installation will meet this condition. The other condition relates to the impedance of the involved transformer. This information can be obtained from the transformer manufacturer.

Following in Figures 1 through 3 are examples using a 6% impedance transformer with a 54 ampere primary (greater than 600 V) and a 180 ampere secondary (less than 600 V). For simplicity, overcurrent protection is shown as simple fuses or circuit breakers. The next standard setting permitted for applications above 600 V is more complex than that for below 600 V; the examples given show the maximum calculated value. Where secondary protection is required, it is shown as a single device; remember that up to six devices may be used, totaling not more than the permitted rating of a single device. The type of OCP shown is for example only.

NOTE: At this point, protection for the conductors has NOT been considered.

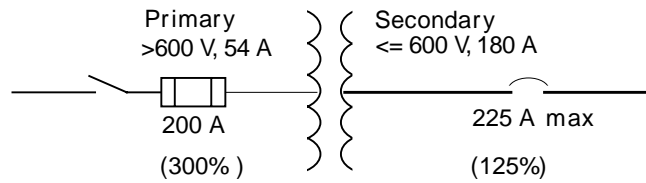

Figure 1: Unsupervised Installation

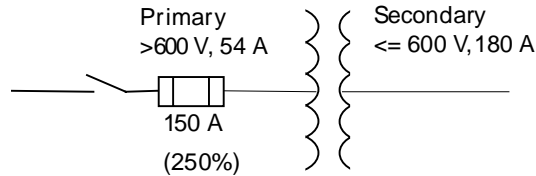

Figure 2: Supervised, Primary Only

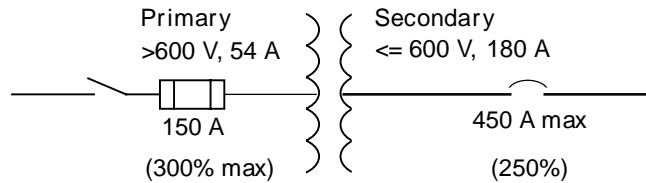

Figure 3: Supervised, Primary and Secondary

Comparing Figures 1 and 3, the notable difference between supervised and unsupervised locations is the increased percentage from 125% to 250% for the secondary OCP. In the examples, Figures 2 and 3 seem redundant because both have 150 A primary fusing. This occurred because in Figure 2 it is permissible to go to the next standard size; in Figure 3 the requirement is to go to the next lower standard size. Had circuit breakers been used to provide primary protection, the values would be considerably different since Figure 2 would have sizing up to 300% and Figure 3 up to 600%.

600 V, Nominal and Less—450.3(B)

These rules apply to transformers where both the primary and secondary are 600 V or less. Table 450.3(B) outlines the requirements for protection of the transformer using a device on the primary only and protection using both primary and secondary protection. Remember, this only covers the transformer, not the conductors.

**Table 2: 450.3(B) Maximum Rating or Setting of Overcurrent Protection for Transformers 600 Volts and Less
(As a Percentage of Transformer-Rated Current)**

| Protection Method | Primary Protection | | | Secondary Protection (See Note 2) | |
|----------------------------------|-------------------------------|------------------------------|------------------------------|-----------------------------------|------------------------------|
| | Currents of 9 Amperes or More | Currents Less than 9 Amperes | Currents Less than 2 Amperes | Currents of 9 Amperes or More | Currents Less than 9 Amperes |
| Primary only protection | 125% (See Note 1) | 167% | 300% | Not required | Not required |
| Primary and secondary protection | 250% (See Note 3) | 250% (See Note 3) | 250% (See Note 3) | 125% (See Note 1) | 167% |

Notes:

- 1 Where 125% of this current does not correspond to a standard rating of a fuse or nonadjustable circuit breaker, the next higher standard rating described in Section 240-6 shall be permitted.
- 2 Where secondary overcurrent protection is required, the secondary overcurrent device shall be permitted to consist of not more than six circuit breakers or six sets of fuses grouped in one location. Where multiple overcurrent devices are utilized, the total of all the device ratings shall not exceed the allowed value of a single overcurrent device. If both breakers and fuses are utilized as the overcurrent device, the total of the device ratings shall not exceed that allowed for fuses.
- 3 A transformer equipped with coordinated thermal overload protection by the manufacturer and arranged to interrupt the primary current, shall be permitted to have primary overcurrent protection rated or set at a current value that is not more than six times the rated current of the transformer for transformers having not more than 6% impedance, and not more than four times the rated current of the transformer for transformers having more than 6% but not more than 10% impedance.

The overcurrent protection for these transformers is fairly straightforward. Figures 4 and 5 illustrate two examples using a transformer with a 90 A-rated primary and a 180 A-rated secondary.

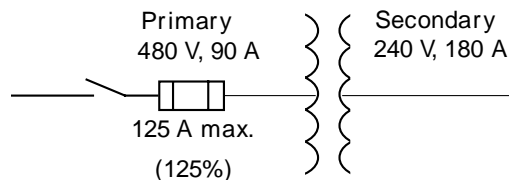

Figure 4: Primary Only

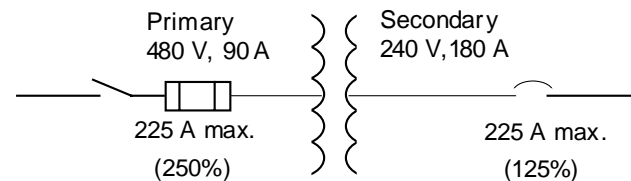

Figure 5: Primary and Secondary

Secondary OCP is required in Figure 5 because the primary is protected at a value greater than 125%. In accordance with Note 2, this 225 A single overcurrent device shown on the secondary can be replaced by up to six overcurrent devices. The total of the six overcurrent device ratings could not exceed 225 A. Further application of this arrangement will be discussed when conductor protection is covered.

PRIMARY AND SECONDARY CONDUCTOR SIZING

Two basic factors that influence the sizing of conductors feeding a transformer follow:

1. Size the conductors adequately to carry the expected primary current of the transformer. Determine allowable ampacity of conductors in accordance with 310.15.
2. Protect conductors in accordance with NEC 240.4 or 240.100.

For circuits operating at or below 600 V, the conductors will generally be larger than the transformer FLA to be protected by the transformer primary OCP in accordance with Section 240.4. In the case of circuits operating above 600 V, the rules in Section 240.100 permit the conductor to be protected by a fuse not greater than three times the conductor rating or a circuit breaker not greater than six times the conductor rating. This matches well with the permitted transformer protection in 450.3(A).

In the example shown in Figure 5, the conductors supplying the transformer need to be at least 4/0 Cu (based on Table 310.16), if equipment with 75 °C terminations is assumed.

Two basic factors influence transformer secondary conductors:

1. Adequate ampacity to carry the load supplied by the secondary of the transformer. Determined in accordance with 310.15.
2. In applications of 600 V or less, overcurrent protection is typically located at the load end of the field installed conductors, NEC 240.21(C) (or Part VIII of Article 240 for supervised industrial installations) has a significant influence on the size of these conductors.

For applications over 600 V, rules similar to those in 240.21(C) are not available. OCP must be provided where these conductors originate or a sensing/relaying scheme will have to be used to open a device ahead of these conductors. In the case of conductors connected directly to the transformer secondary, it may be necessary to open the overcurrent device on the primary of the transformer when the secondary overcurrent sensing means detect an overcurrent condition. NEC 240.100 indicates that the location of the overcurrent protection can be determined under engineering supervision.

LOCATION OF OVERCURRENT PROTECTION FOR TRANSFORMER SECONDARY CONDUCTORS (600 V AND LESS)—240.21(C)

The rules in 240.21(C) are applicable in situations where the secondary voltage is at or below 600 V. These rules intend to deal with the location of the overcurrent protection, but conductor size is influenced when the rules are applied. The rules are, in a practical sense, a set of trade-offs. The designer/installer must meet some additional criteria if the overcurrent protection is not going to be located at the point where the conductors receive their supply. Given that some length of conductor is necessary to connect from most transformer secondaries, the rules in 240.21(C) recognize acceptable means to provide that conductor length.

240.21(C) does not limit the number of taps that are permitted to be made to a transformer secondary. It does specify the rules necessary for each tap.

To see how each of the rules will be applied we will use the following parameters:

- Transformer primary—480 V, 90 A
- Transformer secondary—240 V, 180 A
- All equipment terminations are assumed to be 75 °C

**240.21(C)(1)—Protection by Primary
Overcurrent Device**

In limited circumstances, the transformer secondary conductors can be considered protected by the primary overcurrent device. 240.21(C)(1) outlines the requirements for this application.

- The transformer must be either single-phase and have a 2-wire (single voltage) secondary or it must be a three-phase delta-delta connected arrangement with a 3-wire (single voltage) secondary. The application is limited to these arrangements because faults on the secondary are directly reflected to the primary taking into account the voltage ratio of the transformer.
- The transformer primary overcurrent protection must be in accordance with NEC 450.3.
- The primary OCP size cannot exceed the value determined by multiplying the secondary conductor ampacity by the transformer voltage ratio.

**240.21(C)(2)—Secondary Conductors Not
Over 10 Feet Long**

This rule permits conductors to be connected to a transformer secondary where the following requirements are met:

1. The secondary conductors are not over 10 feet long. This permits 10 feet of conductor for each phase of the transformer. If conductors are paralleled, each of the paralleled conductors may be up to 10 feet in length.
2. The ampacity of the secondary conductors are not less than the combined computed loads on the circuits supplied by the tap conductors AND not less than the rating of the device supplied by the secondary conductors (or not less than the rating of the overcurrent protective device at the termination of the tap conductors).
3. The secondary conductors do not extend beyond the switchboard, panelboard, disconnecting means, or control device they supply. For example, it would not be permitted to supply a MLO panelboard from the secondary and then use thru-feed lugs to supply another panel or device.
4. The secondary conductors are enclosed in a raceway.

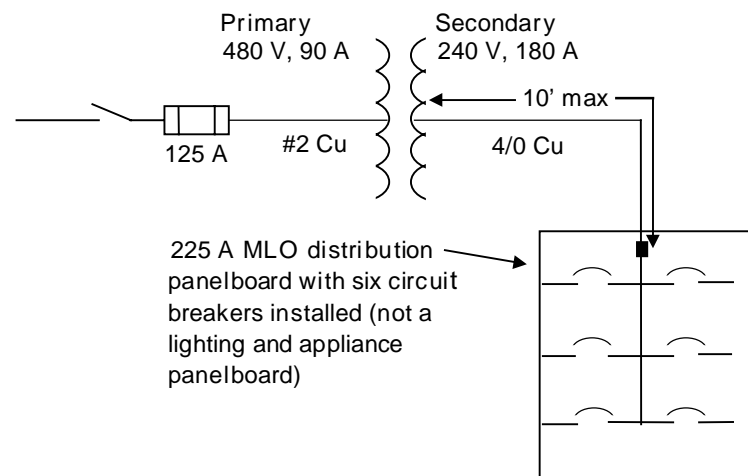

Figure 6: Transformer Secondary Not Over 10 Feet Long

In Figure 6, the transformer does not require secondary overcurrent protection because the primary protection is sized at 125% in accordance with 450.3(B). Had the primary protection exceeded the 125 A value, the secondary would be required to have protection at not more than 125%. This secondary protection could still be accomplished with up to six overcurrent devices provided the sum of their ratings did not exceed 225 A (180×1.25).

Although the rules do not limit the number of sets of transformer secondary conductors, there are rules that limit the number of separate devices that can be supplied from a single set of secondary conductors. Figure 7 shows a typical misapplication of the transformer secondary rules. The 4/0 conductor is connected to the transformer secondary, but is "tapped" in the wireway with #6 AWG conductors to supply separate disconnects. The wording of 240.21 main paragraph indicates that this type of application is not permitted.

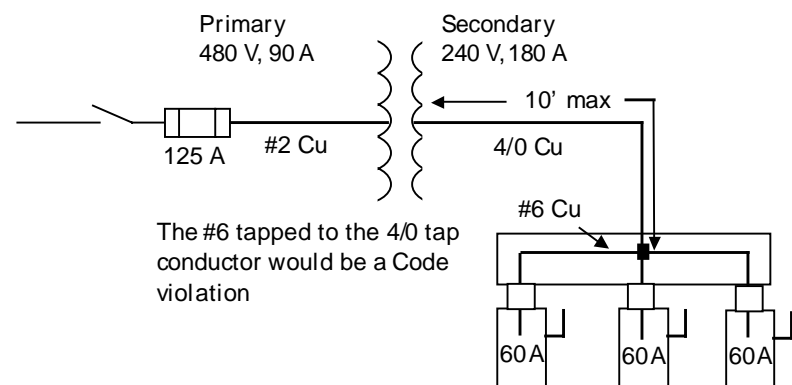

Figure 7: Improper Application of the Rules in 240.21

**240.21(C)(3)—Industrial Installation
Secondary Conductors Not Over 25 Feet
Long**

This tap rule is applicable only to industrial installations. Since this can sometimes be a point of debate, it is recommended that the authority having jurisdiction be contacted prior to application of this section to ensure that there is agreement that the application is considered to be an industrial installation by all those concerned.

The rule permits a transformer with 25-foot secondary conductors when the following requirements are met:

1. Each of the secondary tap conductors do not exceed 25 feet in length.
2. The ampacity of the tap conductors is not less than the secondary current rating of the transformer
3. The sum of the ratings of the overcurrent devices does not exceed the ampacity of the tap conductors.
4. All overcurrent devices are grouped.
5. The tap conductors are suitably protected from physical damage.

The limiting factor in this rule is that the total of the overcurrent device ratings cannot exceed the tap conductor ampacity. It would not be permitted to group these overcurrent devices in separate enclosures and feed each enclosure with a conductor smaller than the tap conductor (see commentary on Figure 7). You could, however, terminate the tap conductors in a switchboard or panelboard that contained multiple overcurrent devices.

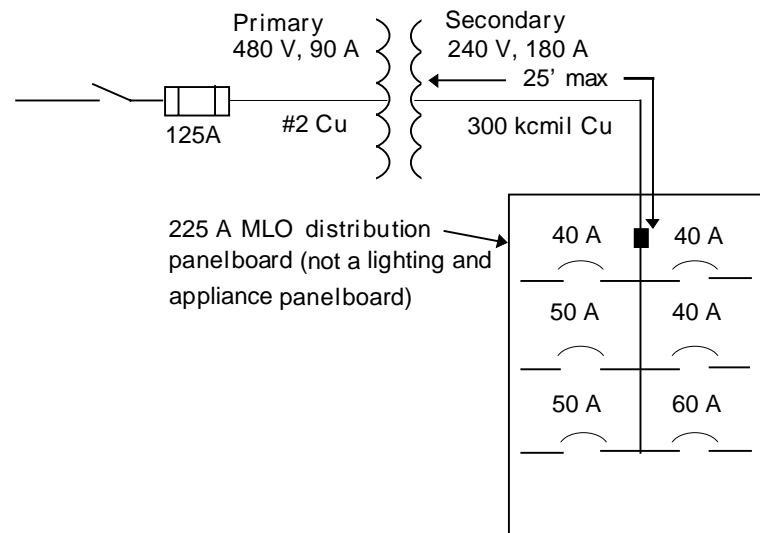

Figure 8: Industrial Installation Secondary Conductors Not Over 25 Feet Long

The significant limitation for the application in Figure 8 is the requirement that the sum of the overcurrent devices at the termination of the tap conductors not exceed the allowable ampacity of the secondary conductors. In that example, the total of the overcurrent devices ratings is 280 A (40 + 40 + 50 + 40 + 50 + 60 = 280), so 300 kcmil conductors with an allowable ampacity of 285 A is required.

The number of overcurrent devices at the termination of the tap conductors is not limited by this tap rule. However, two key items will influence the number of devices permitted by other rules. If the transformer required secondary overcurrent protection (Figure 9 does not since the transformer primary is protected at 125%), then the number of overcurrent devices to make up the secondary protection would be limited to six and the total of the ratings could not exceed $180 \times 1.25 = 225$ A. If the panelboard at the termination of the tap conductors was a lighting and appliance branch circuit panelboard (see NEC 408.14) then the conductors would terminate in a main overcurrent protective device as required by NEC 408.16(A).

240.21(C)(4)—Secondary Outside of a Building of Structure

This rule permits an unlimited length of secondary conductors provided the transformer is located outside of the building and the secondary conductors are routed outside of the building except for the point where they terminate. The following requirements apply to this rule:

1. The secondary conductors must be suitably protected from physical damage.
2. The secondary conductors must terminate in a single circuit breaker or set of fuses that will limit the load to the ampacity of the secondary conductors.
3. The overcurrent device for the secondary conductors is an integral part of the disconnecting means or immediately adjacent thereto.
4. The disconnecting means for the tap conductors is located at a readily accessible location either outside the building or structure or inside nearest the point of entrance of the conductors. NEC 230.6 provides the guidance on what conductor routings can be considered outside of the building.

The drawing below illustrates application of this rule using the same transformer as the earlier examples.

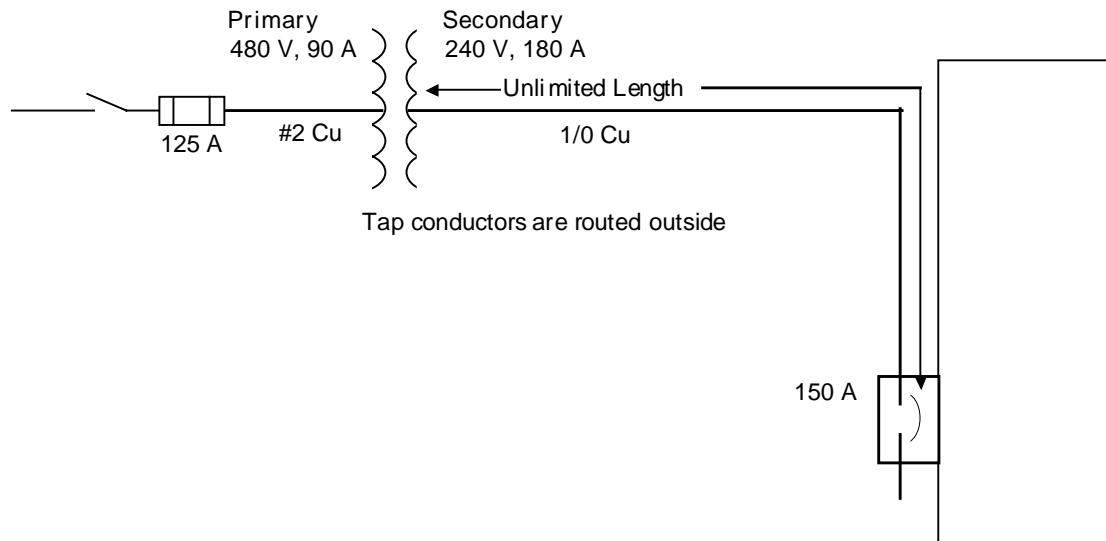

Figure 9: Secondary Outside of the Building or Structure

There is no minimum size tap conductor specified by this tap rule. It must, however, be of sufficient size to be protected from overload by the overcurrent device at its load end. The transformer in Figure 9 does not require secondary protection since the primary is protected at 125%. Had the primary overcurrent protection exceeded this value, secondary protection at not more than 125% would have been required. This protection would also be required to be a single device since the tap rule requires termination in a single device.

240.21(C)(5)—Secondary Conductors from a Feeder Tapped Transformer

This tap rule is unique in that it is the only one that deals with a feeder tap to supply a transformer. This rule works in conjunction with the feeder tap rule outlined in 240.21(B)(3). The following requirements must be met:

1. Conductors supplying the transformer must have an ampacity at least 1/3 the rating of the overcurrent device protecting the feeder conductors.
2. The conductors supplied by the secondary of the transformer must have an ampacity that, when multiplied by the transformer voltage ratio, is at least 1/3 the rating of the overcurrent device protecting the feeder conductors.
3. The total length of one primary plus one secondary conductor is not greater than 25 feet. The 25-foot measurement is permitted to exclude any portion of the primary conductor protected at its ampacity by the feeder overcurrent device.
4. The primary and secondary conductors are protected from physical damage.
5. The secondary conductors terminate in a single overcurrent device (breaker or set of fuses) which will limit the load to the ampacity of the tap conductors.

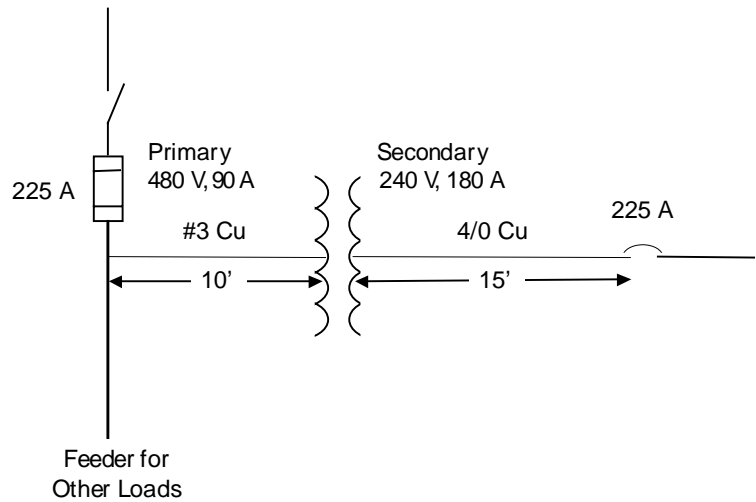

Figure 10: Feeder Tapped Transformer

In Figure 10, the transformer requires secondary overcurrent protection since the primary protection is 250% of the primary current. A close review of Figure 10 shows how the selection of the tap rule used can affect other elements of the system. In this case the transformer secondary overcurrent protection was required to be a single overcurrent device because the secondary tap is required to terminate into a single overcurrent device. Also, since the secondary overcurrent device was selected at 125%, the secondary conductors had to be at least 4/0 in size to correspond with the rating of the overcurrent device. This is necessary even though the transformer can only supply 180 A of secondary current.

240.21(C)(6)—Secondary Conductors Not Over 25 Feet Long

This rule allows a transformer secondary of up to 25 feet long where the following conditions are met:

1. The conductors supplied by the secondary of the transformer must have an ampacity that, when multiplied by the ratio of secondary to primary voltage, is at least 1/3 the rating of the overcurrent device protecting the primary of the transformer.
2. The secondary conductors terminate in a single circuit breaker or set of fuses that are sized not larger than the ampacity of the secondary conductors.
3. The secondary conductors are protected from physical damage.

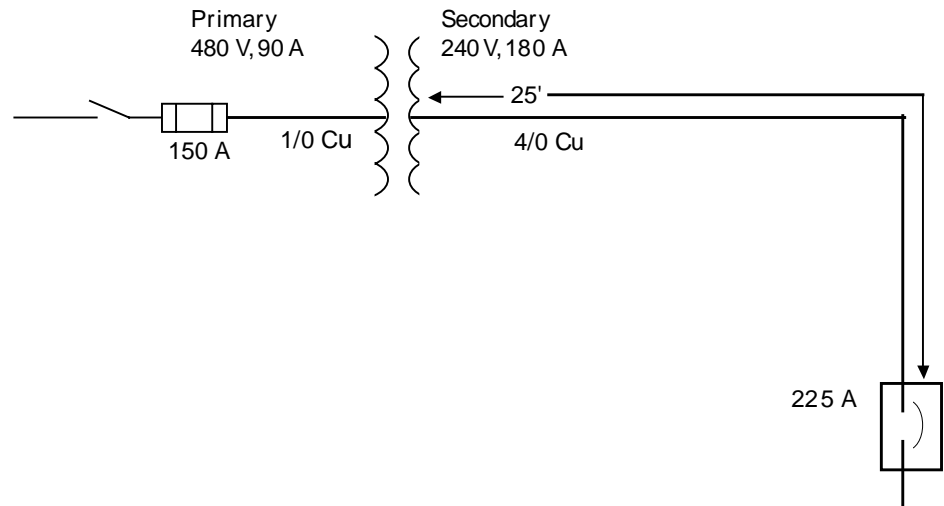

Figure 11: Secondary Conductors Not Over 25 Feet

The transformer shown in Figure 11 does require secondary protection since the primary overcurrent device is sized at more than 125% of the rated primary current. The device at the termination of the secondary conductors serves dual purposes. It meets the requirements for the conductor rule in 240.21(C)(6) because it is not greater than the ampacity of the secondary conductor and it also meets the sizing rule for secondary overcurrent protection in 450.3(B).

Multiple Taps to a Single Transformer

As mentioned earlier, there is no code rule to limit the number of taps made to a transformer secondary. Design of the transformer terminations may provide a physical (as well as a listing) limitation.

The example in Figure 12 shows how multiple taps could be used.

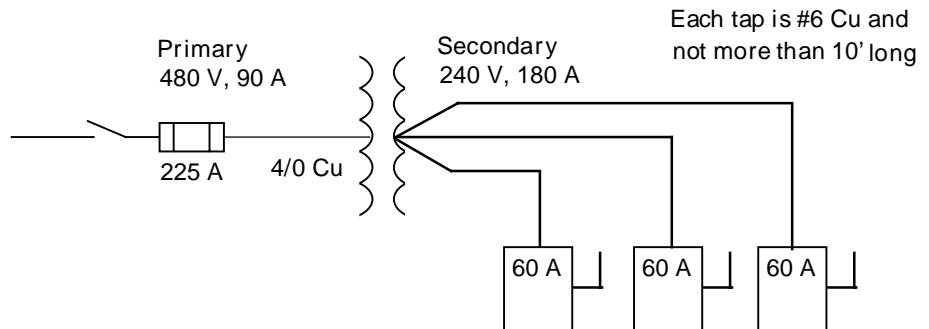

Figure 12: Multiple Taps to a Single Transformer Secondary

In Figure 12, the transformer does require secondary overcurrent protection since the primary protection is sized at 250%. The secondary OCP cannot be larger than 225 A (180 x 1.25). The three sets of 60 A fuses meet the requirement for this protection since they total 180 A (3 x 60). Because the three 60 A devices provide secondary protection for the transformer, they must be grouped to comply with 450.3(B) Note 2."

SUPERVISED INDUSTRIAL INSTALLATIONS

Part VIII of NEC Article 240 provides some specialized rules for supervised industrial installations. The following elements are outlined in 240.2 to define a supervised industrial installation.

1. "Conditions of maintenance and engineering supervision ensure that only qualified persons monitor and service the installation." Note the term "monitor" in the definition. This implies that more than simply having a "qualified" installer is required, the installation must have staff on hand to "monitor" the installation.
2. "The premises wiring system has 2500 kVA or greater of load used in industrial process(es), manufacturing activities, or both, as calculated in accordance with Article 220." Note that the 2500 kVA of load is not permitted to include any office or non-manufacturing portions of the building.
3. "The premises has at least one service that is more than 150 V to ground and more than 300 V phase-to-phase."

240.90 makes it clear that the rules cannot be applied to the portion of the installation that is not used exclusively for manufacturing or process control activities. The intention is to limit these special rules only for the specialized process and manufacturing applications. For example, if a large transformer supplied both a process area of a manufacturing plant as well as the business office areas, the special rules in Part VIII could not be applied to that transformer since it is not "exclusive" to the manufacturing operation.

TRANSFORMER SECONDARY CONDUCTORS OF SEPARATELY DERIVED SYSTEMS

NEC 240.92(B) discusses the secondary conductor protection issues by breaking out the rules for short-circuit/ground-fault protection from those for overload protection. In order to have proper protection, the designer has to make sure that both rules are satisfied.

Short-Circuit and Ground-Fault Protection

240.92(B)(1) recognizes three possible ways to design the system such that the secondary conductors are considered to be protected from short-circuit and ground-fault conditions.

Voltage Ratio Method

The first is outlined in 240.92(B)(1)(1) and permits secondary conductors up to 100 feet in length provided the primary overcurrent device does not exceed 150% of the secondary conductor ampacity times the secondary-to-primary voltage ratio. In the example shown in Figure 13, the secondary conductor ampacity is 230 amperes (determined from Table 310.16). When multiplied by the voltage ratio, the ampacity as viewed from the primary is 115 A. The 150 A primary overcurrent device is within the required 150% ($115 \times 1.5 = 172$ A) sizing. It is important to note that the transformer shown in Figure 13 is required to have secondary protection since the primary device is more than 125% of the rated primary current. We would have to meet the requirement for secondary protection in 450.3(B) by properly selecting our overload protection method in 240.92(B)(2).

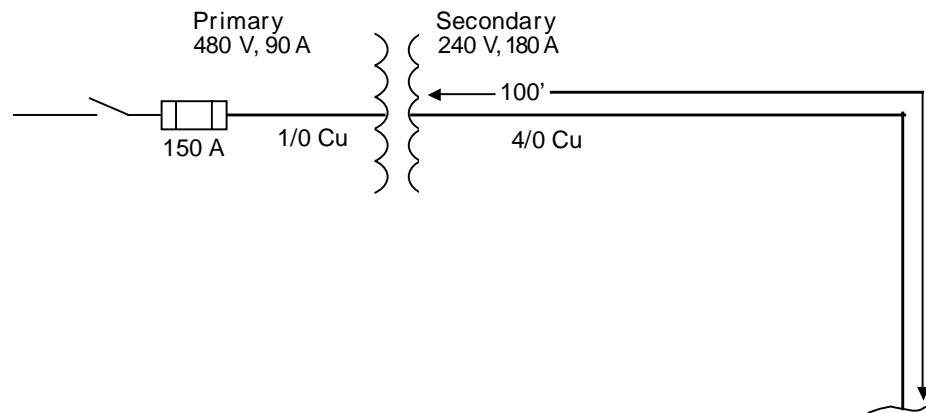

Figure 13: Short-Circuit/Ground Fault-Protection-Voltage Ratio Method

Differential Relay Method

The short-circuit/ground-fault protection requirements in 240.92(B)(1)(2) allows an unlimited length secondary when the conductors are protected by a differential relay with a trip setting equal to or less than the secondary conductor ampacity. In order to provide proper short-circuit protection, the relay would have to open a device on the primary to disconnect power. Otherwise, a fault in the secondary conductors themselves could persist without interruption.

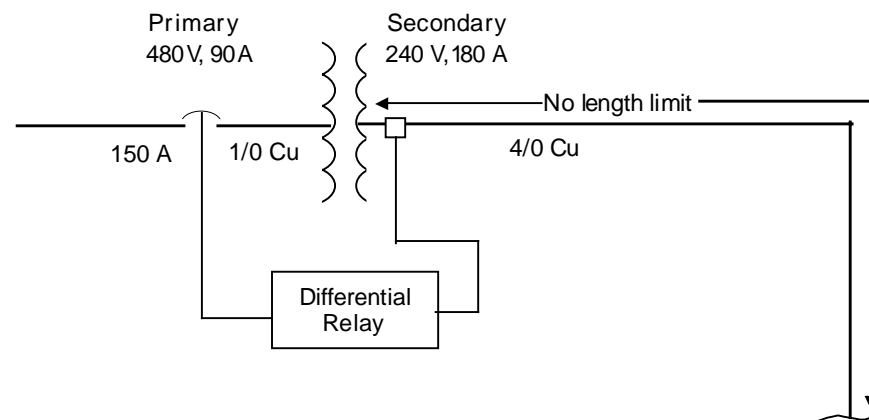

Figure 14: Short-Circuit/Ground Fault-Protection-Differential Relay Method

Engineering Supervision

240.92(B)(1)(3) permits the secondary conductors of a transformer to be considered protected if calculations done under engineering supervision can show that the conductors are protected for ALL short-circuit and ground-fault conditions by the system overcurrent devices. Because the system designs can vary, it is important that the designer consider all fault possibilities including low-level ground faults, high-impedance arcing faults and others. Authorities having jurisdiction should request the detail regarding these calculations and verify that all potential fault modes are covered.

Overload Protection

240.92(B)(2) provides the requirements to consider the transformer secondary conductors protected from overload. Any of these overload methods can be used in conjunction with any of the short-circuit/ground-fault protection methods from 240.92(B)(1).

Single Overcurrent Device

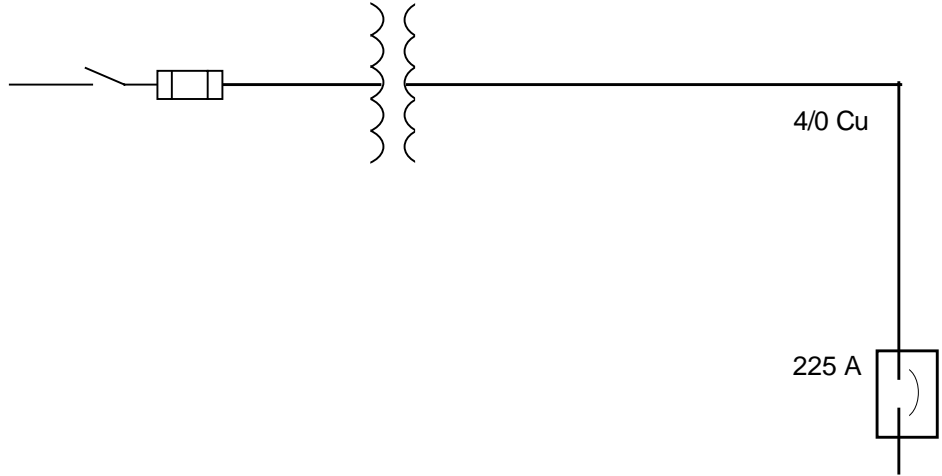

Figure 15: Overload Protection—Single Overcurrent Device

Terminating the conductors in a single overcurrent device that is not greater than the rating of the conductors is the method outlined in 240.92(B)(2)(1).

Not Over Six Overcurrent Devices

240.92(B)(2)(2) allows up to six overcurrent devices to be used for the overload protection.

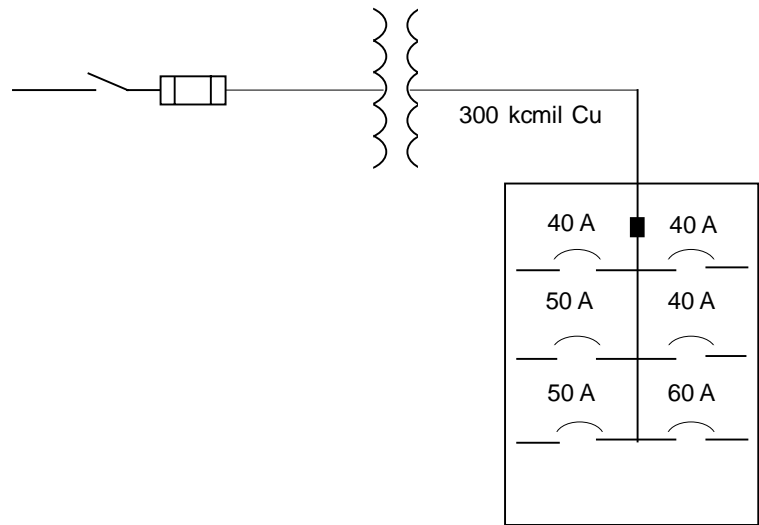

Figure 16: Overload Protection—Not Over Six Devices

The sum of the overcurrent devices cannot exceed the ampacity of the secondary conductors. In Figure 16, the 300 kcmil conductor would have a rating of 285 amps (based on Table 310.16). The six overcurrent devices add up to 280 amps, so the arrangement would meet the requirements for proper overload protection.

Overcurrent Relaying

240.92(B)(2)(3) recognizes the use of overcurrent relays to sense the secondary conductor current and open either the primary or secondary overcurrent device(s).

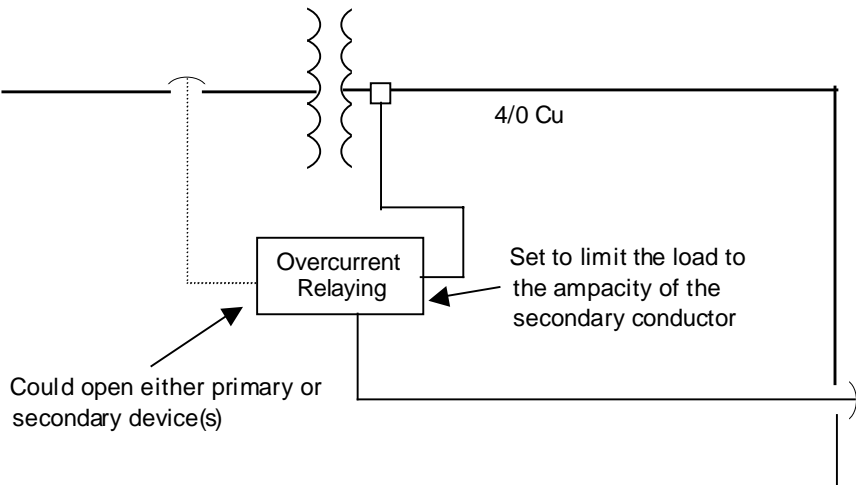

Figure 17: Overload Protection—Overcurrent Relaying

As shown in Figure 17, the relaying scheme must be set to limit the load to the ampacity of the secondary conductors. In this example, the ampacity of the 4/0 would be 230 amps (from Table 310.16).

**OUTSIDE TRANSFORMER
SECONDARIES**

NEC 240.92(C) provides an alternative method for supervised industrial installations to protect the secondary conductors of a transformer located outdoors. The rule permits an unlimited length of secondary conductors provided the transformer is located outside of the building and the secondary conductors are routed outside of the building except for the point where they terminate. The significant difference between this rule and the rules outlined in 240.92(B) is that the six devices at the termination of the conductors can serve to meet both the short-circuit/ground-fault and the overload requirements.

The following requirements apply to this rule:

1. The secondary conductors must be suitably protected from physical damage.
2. The sum of the overcurrent devices at the conductor limits the load to the conductor ampacity. The number of overcurrent devices is limited to six. These can be grouped in separate enclosures or in a single enclosure or a switchboard.
3. The overcurrent device for the secondary conductors is an integral part of the disconnecting means or immediately adjacent thereto.
4. The disconnecting means for the tap conductors is located at a readily accessible location either outside the building or structure or inside nearest the point of entrance of the conductors. NEC 230.6 provides the guidance on what conductor routings can be considered outside of the building.

Figure 18 illustrates application of this rule using the same transformer as the earlier examples.

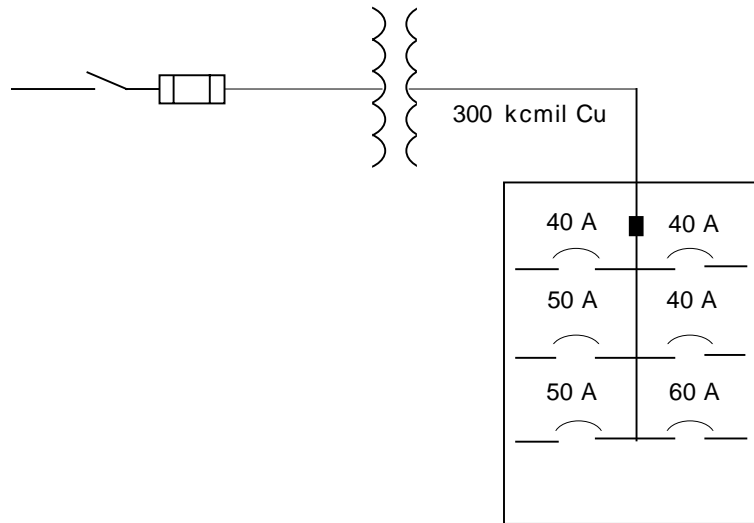

Figure 18: Secondary Outside of the Building or Structure

There is no minimum size tap conductor specified by this tap rule . . . In Figure 18, the 300 kcmil conductor would have a rating of 285 amps (based on Table 310.16). The six overcurrent devices add up to 280 amps, so the arrangement would meet the requirements of 240.92(C).

Protection by Primary Overcurrent Device

The option presented in 240.92(D) allows the conductors on the secondary of a transformer in a supervised industrial installation to be protected by the primary overcurrent device. The primary overcurrent device must be selected such that the time-current characteristic multiplied by the maximum effective primary-to-secondary transformer voltage ratio, *effectively* protects the secondary conductors. The key word in this rule is “effectively”. This will require a great deal of engineering work to make sure that all fault modes and all levels of fault are covered by the primary device sizing. The configuration of the transformer will have an impact as well. For instance, achieving the desired protection will be easier on a 2-wire, single-phase secondary than on a 4-wire, three-phase secondary.

SUMMARY

Transformers, conductors, and overcurrent devices are all separate parts of an electrical installation, however, they function as a system. The rules in the NEC are designed to be used together. When installing a transformer, Article 450 is the place to start, but as soon as conductors are connected, those rules in Article 450 have to be considered in conjunction with the rules in Article 240. Reviewing all of the rules before you begin the installation will facilitate a more time (and ultimately cost) effective installation that complies with the NEC.”

Jim Pauley, P.E.
Square D Company
1601 Mercer Road
Lexington, KY 40511 USA
(859) 243-8000
www.squared.com

Electrical equipment should be serviced only by qualified personnel. No responsibility is assumed by Schneider Electric for any consequences arising out of the use of this material. This document is not intended as an instruction manual for untrained persons.

Bulletin No. 0110DB0201 September 2002 Replaces 0110ED9501 dated 09/95.