

Instruction Bulletin

6055-33
April 1998
Smyrna, TN, USA

Type VR Vacuum Circuit Breaker 4.76 kV, 8.25 kV, and 15 kV 3000 A Class 6055



SQUARE D

CONTENTS	PAGE
1. INTRODUCTION	1
Surge Protection For Type VR Vacuum Circuit Breakers—Statement of Use	1
2. SAFETY PRECAUTIONS	2
3. RECEIVING, HANDLING, AND STORAGE	3
Receiving	3
Handling	3
Storage	3
4. DESCRIPTION	4
Circuit Breaker Rating	4
Indicators	4
Vacuum Interrupters	4
Primary Disconnects	4
Operating Mechanism	4
Closing Springs	6
Opening Springs	6
Control Circuit	6
Auxiliary Switch	8
Motor Limit Switch	8
Spring Charging Motor	9
Anti-Pump Relay	9
Latch Check Switch	9
Motor Cutoff Switch	10
Trip and Close Coils	10
5. INITIAL CIRCUIT BREAKER PREPARATION	11
Inspection	11
Manual Open/Close	11
Hi-Pot test	12
6. INSTALLATION	13
Site Preparation	13
Racking In Procedure	13
7. OPERATION	14
Test Position Operation	14
Closing Spring Charging	14
Closing Operation	15
Opening Operation	15
Racking Out Procedure	15
Locking Provision	15
8. MAINTENANCE	16
General Inspection	16
Insulating Surfaces	16
Vacuum Interrupters	16
Vacuum Interrupter Pole Assembly Replacement	17
Contact Gap	17
Lubrication	18
9. REPLACEMENT PARTS	19
Ordering Instructions	20
10. INSTALLATION AND MAINTENANCE LOG	21

ILLUSTRATIONS	PAGE
1. Circuit breaker with lifting assembly attached	3
2. Circuit breaker, front view	4
3. Circuit breaker, rear view and side view	5
4. Circuit breaker, left front view without cover	5
5. Circuit breaker, right front view without cover	6
6. Control circuit schematic	7
7. Left side of mechanism	8
8. Motor limit switch	8
9. Spring charging motor	9
10. Latch check switch	9
11. Circuit breaker, bottom view	10
12. Trip coil and close coil	10
13. Charging the springs for manual open/close	11
14. Type VR circuit breaker in test position	14
15. Padlock provision	15
16. Spring overtravel	17

TABLES	PAGE
1. Hi-Pot Test Voltages	12
2. E-gap Settings	17
3. Lubrication Chart	18
4. Replacement Parts	19
5. Replacement Parts (continued)	20

SECTION 1—INTRODUCTION

This bulletin provides installation, operation, and maintenance instructions for Type VR medium voltage vacuum circuit breakers manufactured by Square D Company.

This device provides interrupting capability for medium voltage systems up to 15 kV. The Type VR vacuum circuit breaker is a horizontal drawout circuit breaker designed for use with metal-clad switchgear. The specific rating of each circuit breaker is printed on the circuit breaker nameplate.

Surge Protection For Type VR Vacuum Circuit Breakers— Statement Of Use

Circuits in which these circuit breakers are placed are capable of producing overvoltages. The following general guidelines will eliminate the vast majority of application concerns. However, they do not guarantee complete system protection from the occurrence of overvoltages.

- Complex medium voltage systems may require a detailed overvoltage system analysis and the addition of an RC network.
- All circuits should have at least distribution class arresters unless cable lengths exceed 300 feet (91.5 meters). In many cases, external arresters are already used for other reasons. Surge protection is not provided as standard equipment, but is an available option (as necessary per customer specifications).
- For dry-type transformer and motor loads, surge capacitors should be used at the terminals of the transformer or motor. (Cast resin transformers are considered dry-type transformers in this discussion.) Where there are long lengths of cable, the cable capacitance offers surge capacitor protection, provided the cable capacitance is equivalent to typical values available in surge capacitors.

SECTION 2—SAFETY PRECAUTIONS

DANGER

HAZARD OF ELECTRIC SHOCK, BURN, OR EXPLOSION

- Only qualified personnel familiar with medium voltage circuits are to perform work described in this set of instructions. Workers must understand the hazards involved in working with or near medium voltage equipment. Perform such work only after reading this set of instructions in its entirety.
- For this equipment to function properly, it must be handled carefully and installed, operated, and maintained correctly. Neglecting fundamental installation and maintenance requirements may lead to personal injury, as well as damage to electrical equipment or other property.
- Be aware of potential hazards, wear protective equipment, and take adequate safety precautions.
- Do not make any modifications to the equipment or operate the system with the interlocks removed. Contact your local Square D representative for additional instructions if the VR circuit breaker does not function as described in this manual.
- Before performing visual inspections, tests, or maintenance on this device, disconnect all sources of electric power. Assume all circuits are energized until they are completely de-energized, tested, grounded, and tagged. Pay particular attention to the design of the power system. Consider all sources of power, including the possibility of backfeeding.
- Before replacing covers, carefully inspect the circuit breaker work area for tools and objects left inside the equipment.
- All maintenance must be performed by qualified personnel in accordance with local codes and under the following conditions:
 - The circuit breaker must be removed from its cell and isolated from the high voltage.
 - Control voltage must be removed from the controls.
 - The circuit breaker must be in the open position.
 - All circuit breaker springs must be discharged.

All instructions in this manual are written with the assumption that the customer has taken these measures before performing maintenance or testing.

Failure to observe these precautions will result in death or serious personal injury.

SECTION 3—RECEIVING, HANDLING, AND STORAGE

Receiving

Upon receipt, inspect the entire circuit breaker for damage that may have occurred in transit. Check all items against the packing list provided. Immediately notify the carrier and Square D of any damages or shortages.

Handling

Use care when uncrating and handling the circuit breaker. Roll and maneuver the circuit breaker by grasping the top edge of the front cover. When lifting the circuit breaker by a hoist, verify that it is capable of lifting the weight of the circuit breaker, which is approximately 700 lb (315 kg). If not already attached, bolt a lifting assembly onto the circuit breaker as shown in Figure 1. To hoist the circuit breaker, insert hooks through the holes in the lifting assembly. Do not lift without the spreader angle in place. See Figure 1. One lifting assembly is furnished per lineup as standard and is shipped from the factory attached to the circuit breaker.



CAUTION

HAZARD OF EQUIPMENT DAMAGE

- Never lift the circuit breaker by placing forklift bars beneath the circuit breaker frame.
- Ensure that the spreader angle is in place in the lifting assembly when using a hoist to lift the circuit breaker.
- Do not use the main contacts as handles.

Failure to observe these precautions can damage the equipment and will void the warranty.

Storage

If the circuit breaker must be stored before it is put into operation, keep it in a clean, dry, corrosion-free area where it is protected from damage. Place the circuit breaker in its permanent location as soon as possible. If the circuit breaker will be used in switchgear employing space heaters, install it only after the heaters are operating.

When circuit breakers are stored for prolonged periods, inspect them regularly for rusting and overall condition. Lubricate when necessary. Refer to “Lubrication” in section 8.

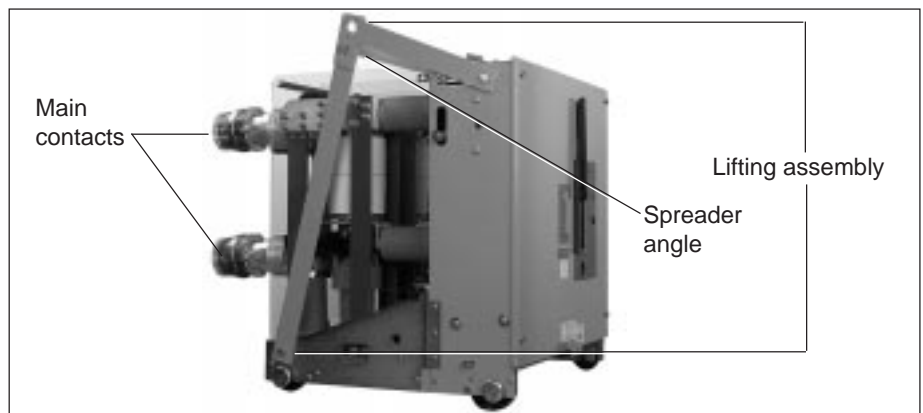

Figure 1: Circuit breaker with lifting assembly attached

SECTION 4—DESCRIPTION

Circuit Breaker Rating	The circuit breaker ratings are printed on the rating nameplate (figure 2).
Indicators	The operating mechanism has two indicators. The open-closed indicator (figure 2) shows whether the vacuum interrupter contacts are open or closed. The charged-discharged indicator (figure 2) shows whether the closing springs are charged or discharged.
Vacuum Interrupters	Vacuum interrupters (figure 3), which are mounted vertically on the back side of the circuit breaker frame, perform the circuit breaker interruption. Consisting of a pair of butt contacts, one movable and one fixed, the vacuum interrupters require only a short contact gap for circuit interruption.
Primary Disconnects	The primary connection to the associated switchgear is through the six primary disconnects (figure 3) mounted horizontally at the rear of the circuit breaker. Never use the primary disconnects as handles when maneuvering the circuit breaker.
Operating Mechanism	The operating mechanism (figure 4) is a stored energy type mechanism. It uses charged springs to perform circuit breaker opening and closing functions. The operating mechanism contains all necessary controls and interlocks. It is mounted at the front of the circuit breaker for easy access during inspection and maintenance.

NOTE: To remove the mechanism cover (figure 2), carefully unclip the back of the cover from the mechanism frame.



Figure 2: Circuit breaker, front view



Figure 3: Circuit breaker, rear view and side view

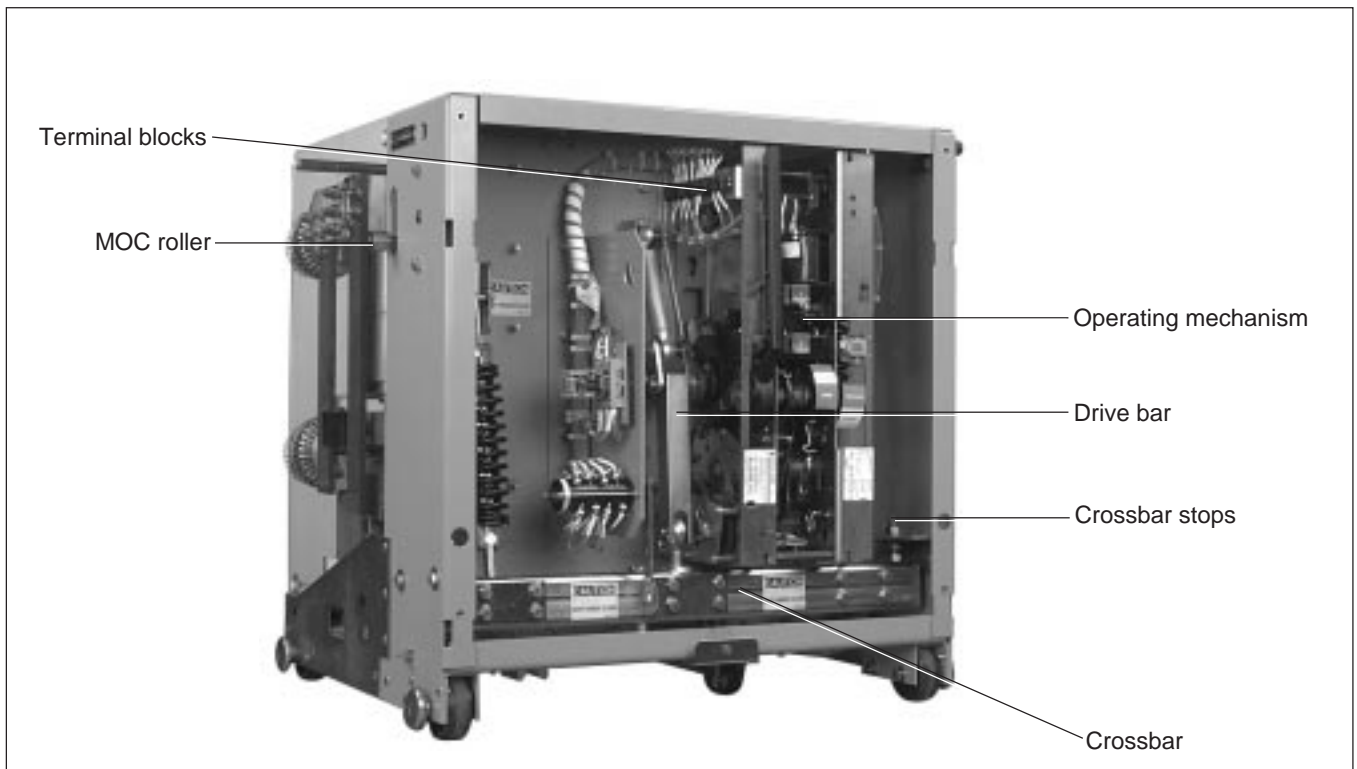

Figure 4: Circuit breaker, left front view without cover

Closing Springs

The closing springs (figure 5) close the circuit breaker when the close pushbutton is pressed or when the closing coil is energized. These springs are charged (compressed) either manually with the manual charging arm (figure 2, page 4) or electrically by the spring charging motor.

When control power is applied to the circuit breaker, the spring charging motor is energized. The charging motor turns the gear box gears which drive the ratchet assembly up and down.

The ratchet assembly rotates the drive shaft compressing the closing springs. As the springloads pass top-dead center, the drive shaft rotates a few degrees until the closing latch roller engages the closing latch. The drive shaft can rotate no further; the closing springs are held in this charged position until a closing operation is initiated by the close pushbutton or closing coil.

Opening Springs

The opening springs (figure 5) open the circuit breaker when the open pushbutton is pressed or the opening coil is energized. These springs are compressed whenever the circuit breaker is in the closed position.

Control Circuit

Figure 6 shows a typical schematic diagram for the control circuit of the Type VR circuit breaker. The following paragraphs describe the control circuit components. The control circuit design may vary, depending upon customer requirements. Always refer to the schematic diagram for the specific equipment in question.



Figure 5: Circuit breaker, right front view without cover

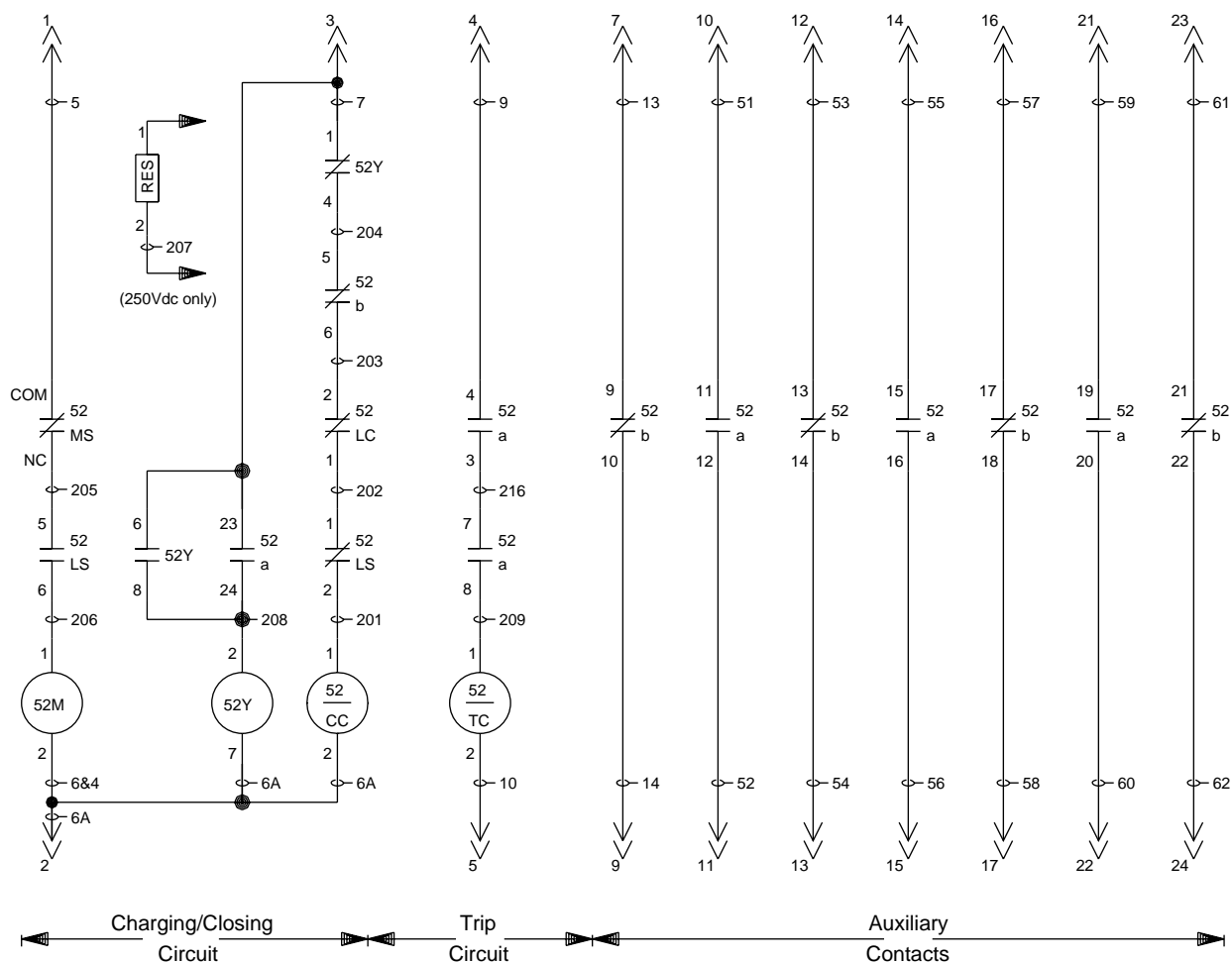

LEGEND	
52M	Spring Charging Motor
52Y	Anti-Pump Relay
52/a	Aux. Switch, Open When Breaker Open
52/b	Aux. Switch, Closed When Breaker Open
52/CC	Close Coil
52/LC	Latch Check Switch
52/LS	Motor Limit Switch
52/MS	Motor Cutoff Switch
52/TC	Trip Coil
RES	Resistor (250Vdc Closing Only)

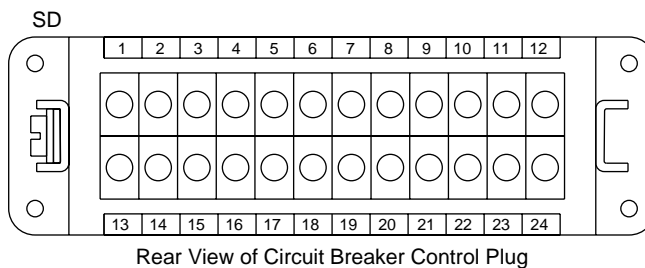

Rear View of Circuit Breaker Control Plug

1 = 5 (MS-COM)	9 = 14 (AS-10)	17 = 58 (AS-18)
2 = 6A (Y-7)	10 = 51 (AS-11)	18 = 28 (TBM-11)
3 = 7 (Y-1)	11 = 52 (AS-12)	19 = 29 (TBM-12)
4 = 9 (AS-4)	12 = 53 (AS-13)	20 = 27 (TBM-13)
5 = 10 (TBM-10)	13 = 54 (AS-14)	21 = 59 (AS-19)
6 = 4 (TBM-4)	14 = 55 (AS-15)	22 = 60 (AS-20)
7 = 13 (AS-9)	15 = 56 (AS-16)	23 = 61 (AS-21)
8 = 8A (TBM-8)	16 = 57 (AS-17)	24 = 62 (AS-22)

Figure 6: Control circuit schematic

Auxiliary Switch

The auxiliary switch (figure 7) is a multi-stage switch used to operate circuits that depend on the position of the circuit breaker contacts. The schematic diagram illustrates how each of the auxiliary switch contacts interconnect with the circuit breaker circuitry. The auxiliary switch functions as follows:

- Two a-type auxiliary contacts connect in series with the trip coil. Because these stages are open when the circuit breaker is in the open position, the auxiliary contacts de-energize the trip coil when the circuit breaker is in the open position.
- The b-type contact, connected in series with the closing coil, de-energizes the closing coil when the circuit breaker contacts are in the closed position.
- As shown, several a-type and b-type auxiliary contacts are provided for optional use.

Motor Limit Switch

The motor limit switch (figure 8) energizes the spring charging motor when a closing spring charging operation is required. The motor limit switch de-energizes the spring charging motor when the closing springs reach the fully charged position.

As shown in the schematic diagram, the motor limit switch is connected to the motor in the normally open position. When the closing springs are in the discharged position, the motor limit switch cam actuates the motor limit switch. This energizes the motor and disables the closing coil. Once the closing springs are fully charged, the cam allows the switch to assume the open position, de-energizing the spring charging motor.

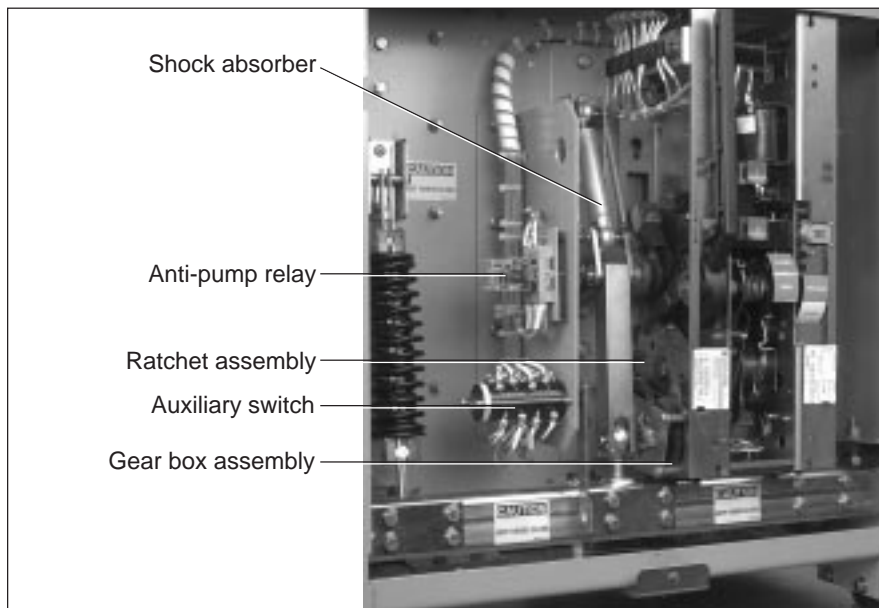

Figure 7: Left side of mechanism



Figure 8: Motor limit switch

Spring Charging Motor

When energized by the closing of the motor limit switch, the spring charging motor (figure 9) drives the series of connected gears. These gears in turn raise and lower the ratchet assembly and rotate the drive shaft.

As the drive shaft rotates, the closing springs compress to the charged position. When the closing springs are fully charged, the motor limit switch contacts reopen, de-energizing the spring charging motor.

Anti-Pump Relay

If the closing coil circuit is continuously energized, the anti-pump relay (figure 7) ensures that the circuit breaker does not “pump” open and closed in the event that a trip signal is also present. The anti-pump relay performs this function by allowing the closing coil to activate only if:

- the circuit is energized
- the closing springs are fully charged, and
- the spring charging motor is de-energized

The anti-pump relay activates when the close circuit and spring charging motor are energized. If the close circuit is energized continuously, the anti-pump relay will be latched in the energized position after the motor is de-energized. When the anti-pump relay is energized, a pair of its normally closed contacts, in series with the closing coil, ensure that the closing coil cannot be energized. The closing coil activates only when the closing circuit is de-energized (de-energizing the anti-pump relay), then closed again.

Latch Check Switch

The latch check switch (figure 10) allows the circuit breaker to be used for reclosing applications. The contacts of the latch check switch connect in series with the closing coil. When the trip latch moves out of its normal position, it activates the latch check switch. The closing circuit cannot be energized until the trip latch fully returns to its normal position and the mechanism is in position to allow a close operation.



Figure 9: Spring charging motor

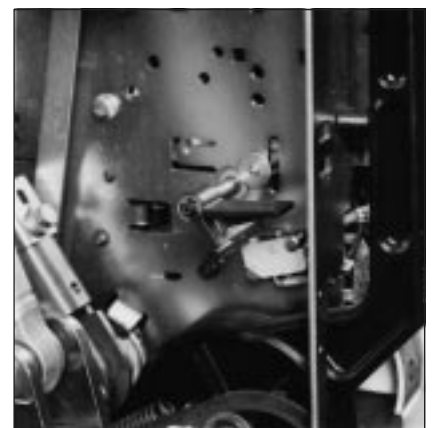

Figure 10: Latch check switch

Motor Cutoff Switch

The motor cutoff switch (figure 11) is located under the base of the Type VR circuit breaker. The motor cutoff switch de-energizes the spring charging motor circuit during racking of the circuit breaker or removal from the cell.

Trip and Close Coils

The standard location of the trip and close coils (figure 12) is in the upper center of the operating mechanism. When energized by the switchgear or remote circuitry, these coils release the open or close latches located inside the mechanism.

NOTE: Optional tripping and closing functions could require that these coils be located on the outside of the mechanism frame.

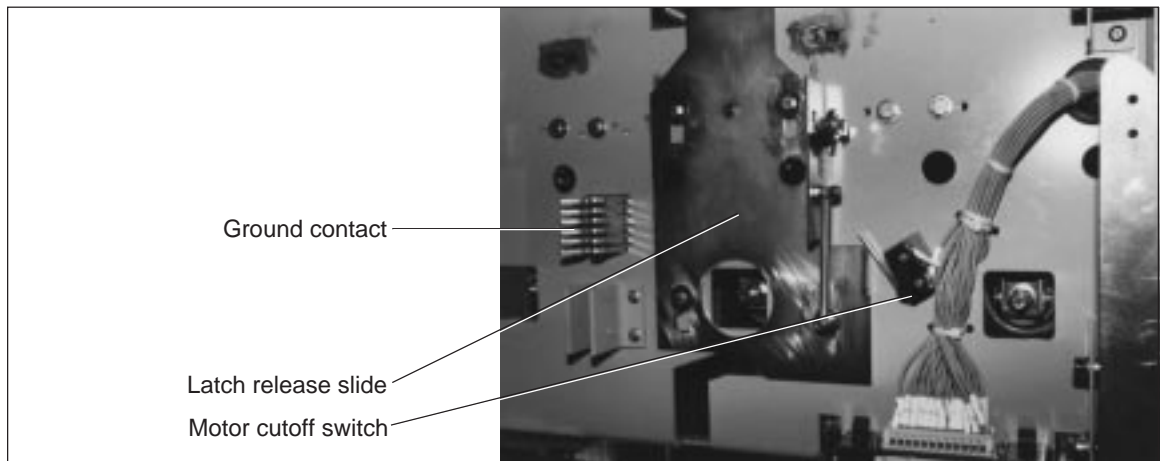

Figure 11: Circuit breaker, bottom view

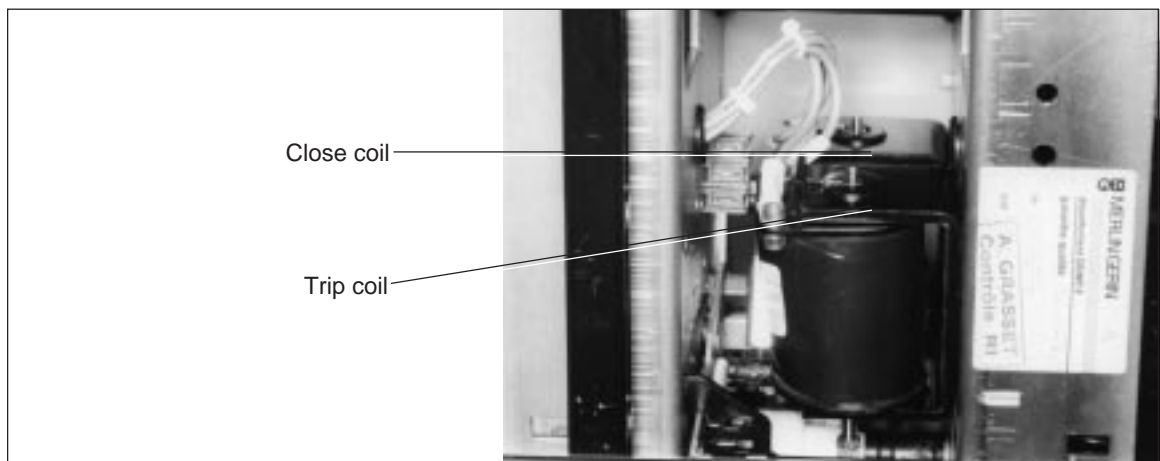

Figure 12: Trip coil and close coil

SECTION 5—INITIAL CIRCUIT BREAKER PREPARATION

Before installing the circuit breaker into the cell in the switchgear, perform the preparation and checkout procedures in this section.

Inspection

1. Examine the entire circuit breaker for damage, dirt, and moisture.
2. Use a clean, dry cloth to remove dirt and moisture that may have collected on the insulating parts.

Manual Open/Close

Manually open and close the circuit breaker several times to verify proper operation. Proceed as follows:

1. Check the indicators (figure 13) to verify that the circuit breaker is in the open position with all springs discharged. If it is not in this position, press the **OPEN**, **CLOSE**, and **OPEN** pushbuttons.
2. Pull the manual charging arm (figure 13) all the way down and back up to the starting position. Repeat this process until the springs are fully charged. They are fully charged when the charging arm resists any further motion and **CHARGED** is visible in the indicator window.
3. Press the **CLOSE** pushbutton to close the circuit breaker.
4. Press the **OPEN** pushbutton to open the circuit breaker.
5. Repeat steps 1–4 at least three times to verify proper operation.

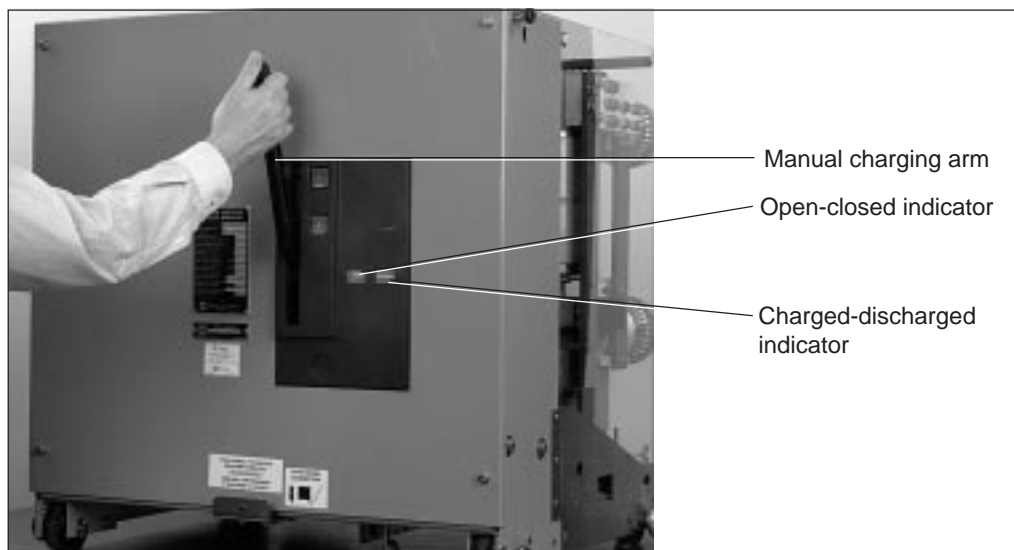



Figure 13: Charging the springs for manual open/close

Hi-Pot test

 **DANGER**

HAZARD OF PERSONAL INJURY OR EQUIPMENT DAMAGE

When performing the hi-pot test:

- Do not exceed the voltages specified in Table 1.
- Keep all people at least six feet away from the circuit breaker being tested.
- Discharge to ground the primary disconnects and the vacuum interrupter mid band ring before handling. These areas can retain a static charge after a hi-pot test.

Failure to observe these precautions will cause death or severe personal injury.

To ensure that no damage has occurred during shipment, check the circuit breaker as follows:

1. Perform a hi-pot test across the open contacts of each vacuum interrupter.
2. With the circuit breaker in the closed position, perform a phase-to-ground and phase-to-phase hi-pot test for each pole.
3. Gradually increase the voltage to the levels indicated in Table 1.

Table 1 Hi-Pot Test Voltages

Equipment Rating	Field Test Voltage	
	AC	DC
5 kV	14 kV	20 kV
15 kV	27 kV	38 kV

4. Verify that the circuit breaker sustains the specified voltage without flashover for one minute. If it does not, inspect the insulators for leakage paths. If necessary, clean the surface of each insulator and repeat steps 1–3. If test voltages are still outside the range in Table 1, contact Square D.
5. Discharge the primary disconnects and vacuum interrupters to ground.

SECTION 6—INSTALLATION

Site Preparation

Refer to site preparation procedures in the switchgear instruction bulletin. Before inserting the Type VR circuit breaker into the cell, make sure the rating of the vacuum circuit breaker matches the rating of the cell.

Racking In Procedure

For convenience, the racking in procedure is included here. Refer to the appropriate switchgear instruction bulletin for complete details.

1. Roll the Type VR circuit breaker into the correct circuit breaker cell.
2. To operate the circuit breaker in the test position (with the primary contacts still disconnected), refer to “Test Position Operation” in section 7.
3. To move the circuit breaker into the connected position, rotate the racking shaft (located in the floor of the circuit breaker cell) clockwise using a Square D approved racking handle.

The circuit breaker must be in the open position when it is racked into or out of its cubicle. The circuit breaker mechanism interlocks with the racking assembly allowing the racking shaft to rotate only when the circuit breaker is in the open position.

4. Rotate the racking shaft until the racking mechanism stops and the position indicator reads CONNECTED.

NOTE: Do not over-torque the racking shaft. During the last one to two inches (25 to 50 mm) of travel (to the connected position), the 3000 A circuit breaker will require more torque than the 1200/2000 A circuit breaker. This is normal. Keep the racking shaft as straight as possible while racking 3000 A circuit breakers.



CAUTION

HAZARD OF EQUIPMENT DAMAGE

Verify that the Type VR circuit breaker is installed in the proper cell.

Failure to observe this precaution can cause equipment damage.

SECTION 7—OPERATION

Test Position Operation

The secondary disconnect (figure 3) mounts on a retractable slide so that it can connect the circuit breaker to the control circuit of the cell before the primary connections are made. This provides a convenient method for electrically testing the operation of the circuit breaker mechanism.

To operate the circuit breaker in the test position:

1. Roll the circuit breaker into the test position of the cell (figure 14). Do not rack the circuit breaker into the cell.
2. Locate the secondary disconnect handle in the floor of the cell (figure 14). Rotate it 90° and pull it straight out until the control plug inserts into the back of the circuit breaker.
3. The control circuit of the circuit breaker is now connected with that of the cell. If the control circuit is energized, this connection immediately activates the spring charging motor inside the circuit breaker. The circuit breaker may now be operated either electrically or manually.

Closing Spring Charging

Pull the manual charging arm (figure 14) all the way down and back up to the starting position. Repeat this process until the closing springs are fully charged. They are fully charged when the charging arm resists any further motion and CHARGED is visible in the indicator window. If the circuit breaker is connected to an energized control circuit, the spring charging motor will automatically charge the closing springs and manual charging is not necessary.



Figure 14: Type VR circuit breaker in test position

Closing Operation

After charging the closing springs, close the circuit breaker by pressing the **CLOSE** pushbutton or energizing the closing coil. The **CLOSE** pushbutton releases the closing latch allowing the closing springs to discharge. The closing springs push down on the crossbar, which is connected to the vacuum interrupters, closing the vacuum interrupter contacts.

Opening Operation

If the circuit breaker is in the closed position, the opening springs will automatically be charged (compressed). If the open pushbutton is pressed or the opening coil is energized, the mechanism releases the opening latch and allows the opening springs to discharge. The opening springs pull up on the crossbar, which is connected to the vacuum interrupters, opening the vacuum interrupter contacts.

Racking Out Procedure

1. Open the circuit breaker by pressing the **OPEN** pushbutton.
2. Place the racking handle onto the racking shaft. Use only a Square D approved racking handle.
3. Rotate the racking handle counterclockwise until the racking mechanism stops and the position indicator reads **TEST/DISCONNECTED**. Do not over-torque the racking shaft.
4. To remove the circuit breaker from a lower cell, open the front door and pull the cell release handle on the lower front of the circuit breaker. Roll the circuit breaker out of the cell and onto the floor.

Locking Provision

The racking mechanism located in the cell floor can be locked with a padlock, as shown in figure 15.



Figure 15: Padlock provision

SECTION 8 —MAINTENANCE

Because Type VR circuit breakers are used in a variety of applications and environments, maintenance schedules should be developed for the particular end use. Until then, inspect circuit breakers after three years or every 3,000 operations, whichever occurs first. Also inspect circuit breakers after severe fault operations and record any contact erosion (see below). This section covers proper inspection and maintenance procedures for Type VR circuit breakers.



WARNING

HAZARD OF PERSONAL INJURY OR EQUIPMENT DAMAGE

Before performing any maintenance or repair work:

- Always remove the circuit breaker completely from the cell.
- Press OPEN, CLOSE, and OPEN pushbuttons to discharge all springs.

Failure to observe these precautions can cause death or severe personal injury.

General Inspection

Visually inspect the entire circuit breaker and operating mechanism for obvious loose parts or connections. Examine the circuit breaker for evidence of overheating or excessive dirt or moisture.

Insulating Surfaces

Using a clean, dry cloth, remove all dirt and moisture from the outside of the vacuum interrupters and from the insulating parts.

Vacuum Interrupters

NOTE: This topic is included for information only. It is not necessary to make any adjustments on a new circuit breaker nor is it required for routine maintenance.

To verify the proper operation of the circuit breaker and the vacuum interrupters, perform the following checks. If the measurements consistently differ from the target values, contact the factory regarding corrective procedures.

1. **Contact erosion:** Contact erosion is the difference between the spring overtravel currently measured and the original factory measurement. When contact erosion exceeds 0.12 inch (3.1 mm), the vacuum interrupter may need to be replaced. Contact the factory for information.

To measure spring overtravel, place the circuit breaker in the closed position. The spring overtravel (E-gap, figure 16) for a new vacuum interrupter assembly should be the distance shown in Table 2. Perform this measurement with a standard pin gauge.

Table 2
E-gap Settings

Short Circuit Current Rating	Initial E-gap	End of Life E-gap
All	0.19 in (4.8 mm)	0.07 in (1.8 mm)

NOTE: The spring overtravel (E-gap) is factory set and should only be adjusted when installing a new vacuum interrupter pole assembly.

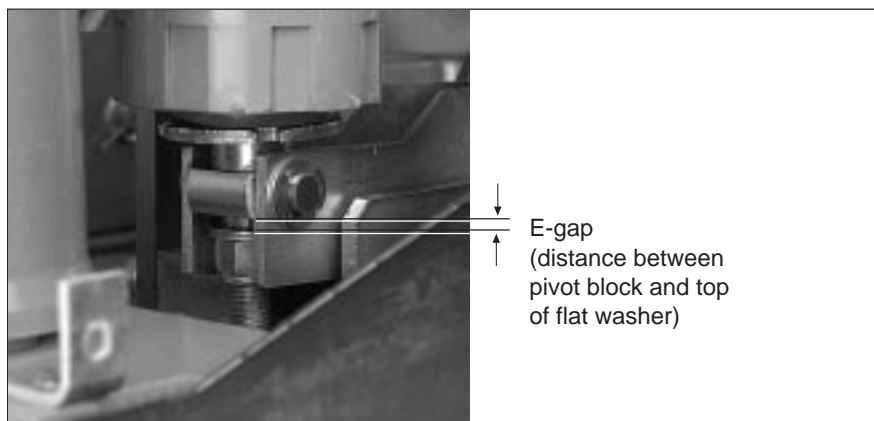

Figure 16: Spring overtravel

2. **Dielectric test.** Perform a hi-pot test on the circuit breaker according to the instructions in **Section 5—Initial Circuit Breaker Preparation**. Consistent unacceptable test results may indicate a loss of vacuum and the vacuum interrupter may need to be replaced. Contact the factory at the address on the back cover for information.
3. **Resistance Measurement.** The resistance measurement from the upper conductor to the lower conductor on each phase of the circuit breaker when it is closed should not exceed 50 micro ohms using a low-resistance ohm meter. A reading exceeding 50 micro ohms indicates that either a poor connection exists or that the vacuum interrupter has reached the end of its life cycle. The vacuum interrupter may need to be replaced. Contact the factory at the address on the back cover for information.

Vacuum Interrupter Pole Assembly Replacement

If a vacuum interrupter pole assembly must be replaced because of severe interruptions, hi-pot test results, or high resistance, contact the factory at the address on the back cover for information about pole assembly replacement.

Contact Gap

The contact gap measurement is not required on a new circuit breaker or as part of routine maintenance. If pole replacement is necessary, the contact gap measurement and setting information will be provided by the factory. Contact the factory at the address on the back cover for information.

Lubrication

The lubrication chart in Table 3 gives the location of each lubrication point and the method of lubrication required. Under normal conditions, lubricate after 3,000 operations or three years, whichever occurs first.

More adverse conditions may require more frequent lubrication intervals and different procedures. Any variations should be based on the experience of the operating company.



WARNING

HAZARD OF PERSONAL INJURY OR EQUIPMENT DAMAGE

Disassembly and reassembly of this circuit breaker without following proper procedures can cause improper operation, resulting in damage to the circuit breaker and injury to the operator.

Failure to observe this precaution can cause death or severe personal injury.

**Table 3
Lubrication Chart**

Lubrication Point	Method of Lubrication During Maintenance Period
Gear teeth in charging motor gear box	Wipe clean and apply lubricant.*
Contact surfaces on guide cams and trip latch	Wipe clean and apply lubricant.*
MOC linkage	Wipe clean and apply lubricant.*
Primary disconnect contacts	Wipe clean and apply contact grease, such as Mobilux EP-1, Square D part number 1615-100790.

* Use Mobilgrease 28, Square D part number 1615-100950, or equivalent.

SECTION 9—REPLACEMENT PARTS

Tables 4 and 5 list factory-recommended replacement parts. Each replacement part is shipped with complete assembly and adjustment instructions.

NOTE: Standard hardware components are not listed and should be purchased locally.

Table 4: Replacement Parts

Description	Part No.	Rated Voltage
Charging Motor and Gear Box Assembly	46040-476-50	48 Vdc
	46040-476-51	125 Vdc
	46040-476-52	250 Vdc
	46040-476-51	120 Vac
	46040-476-52	240 Vac
Anti-Pump Relay	46040-477-50	48 Vdc
	46040-477-51	125 Vdc
	46040-477-52	250 Vdc
	46040-477-53	120 Vac
	46040-477-54	240 Vac
Undervoltage Trip Coil	46040-491-50	24 Vdc
	46040-491-51	48 Vdc
	46040-491-52	125 Vdc
	46040-491-53	250 Vdc
	46040-491-54	120 Vac
	46040-491-55	240 Vac
Contact Finger Assy (3000A)	46001-445-51	—
Ground Contact	46040-482-50	—
Latch Check Switch	46040-483-50	—
Auxiliary Switch	46040-484-50	—
Motor Limit Switch	46040-485-50	—
Motor Cutoff Switch	46040-486-50	—
Shock Absorber	46040-487-50	—
Mechanism Cover	46040-488-50	—

(Continued on page 20.)

Table 5: Replacement Parts (continued)

Description	18 kA Part No.	All other kA Part No.	Rated Voltage
Closing Coil	46040-478-50	46040-478-60	48 Vdc
	46040-478-51	46040-478-61	125 Vdc
	46040-478-52	46040-478-62	250 Vdc
	46040-478-53	46040-478-63	120 Vac
	46040-478-54	46040-478-64	240 Vac
	Trip Coil	46040-479-50	46040-479-60
46040-479-51		46040-479-61	48 Vdc
46040-479-52		46040-479-62	125 Vdc
46040-479-53		46040-479-63	250 Vdc
46040-479-54		46040-479-64	120 Vac
46040-479-55		46040-479-65	240 Vac
Dual Trip Coil	46040-480-50	46040-480-60	24 Vdc
	46040-480-51	46040-480-61	48 Vdc
	46040-480-52	46040-480-62	125 Vdc
	46040-480-53	46040-480-63	250 Vdc
	46040-480-54	46040-480-64	120 Vac
	46040-480-55	46040-480-65	240 Vac

Ordering Instructions

When ordering replacement parts:

- Always specify the complete rating information and circuit breaker serial number.
- Specify part number, description of part, and the catalog from which this information is taken.
- For electrical components specify operating voltage also.

Square D Company
330 Weakley Rd.
Smyrna, TN 37167 USA
(615) 459-5026

Electrical equipment should be serviced only by qualified electrical maintenance personnel. No responsibility is assumed by Square D for any consequences arising out of the use of this material.

Square D and  are registered trademarks of Square D.

Bulletin No. 6055-33 © 1997 Square D All Rights Reserved.